

The Scott News

Vol. 8

AUGUST, 1935

No. 5

HOW TO CHECK TONAL REALISM BY STARTLING NEW TEST



COMPARATIVE LISTENING TEST FOR VOICE



COMPARATIVE LISTENING TEST FOR MUSIC

A RECENT purchaser of one of our new receivers visited the laboratory a few weeks ago, and described a test he had made in his home with his new set, which I believe is one of the most convincing and practical proofs of the startling degree of perfection that has been obtained in the reproduction of musical sounds and tones.

Fortunately, it is a test that can also be carried out by the great majority of our readers in their own homes. To make it, all you require is a radio receiver, and some friend who is either a musician or a vocalist.

Have the musician or singer stand beside the radio, then seat yourself at the end of the room opposite the radio, with your back turned toward them.

First, have your friend play or sing a num-

ber of selections. In the case of an instrument such as a violin, listen particularly for the higher singing notes as well as the tones in the middle and lower registers. When listening to the vocalist, pay particular attention to the natural sound of words ending in "ing", "ed", and "s".

When your ear has become thoroughly accustomed to all of the various tones or notes produced by the instrument being played in your room, then tune in a first class orchestra and listen critically to the notes played by the same type of instrument as the one being played for you.

You will be amazed to discover, when you listen for them, that most of the higher tones or notes are either **SUBDUED OR MISSING ENTIRELY**. While the selections on the various instruments may sound pleasing to your

ear, this test will quickly make you realize the tremendous difference there is between the sound of music played from instruments in your presence, and those same instruments heard thru an ordinary radio.

Read on the following pages why, in a test of this type, there is no loss of realism when music or voice is heard from a high quality broadcasting station and reproduced thru the new **SCOTT FULL RANGE HIGH FIDELITY RECEIVER**.

The First Radio Receiver to Reproduce Perfectly the Full Range of Every Musical Instrument and the Natural Tone of the Human Voice

WHEN you buy a radio receiver you want all of it—and would most certainly object if only half of it was delivered to your home. Yet half a radio is all you get when you buy one that will not reproduce all of the frequencies audible to the human ear. In order to fully appreciate what Full Range High Fidelity reproduction

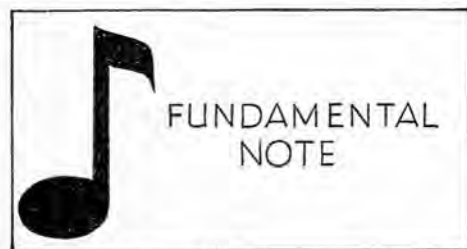

FIG. 1

gives you, and what you miss in a radio receiver that does not have full range reproduction, you will find it interesting to delve a little into the mystery of music and sound.

All sounds produced by musical instruments start from a fundamental note. (See Fig. 1.) This fundamental note is produced by striking a string or setting into motion



FIG. 2

the air column of an instrument. Added to the fundamental note, however, are a number of harmonics or overtones, and it is these that give the various musical instruments their individuality. (See Fig. 2.) Without these overtones, all musical instruments, and the voices of all speakers or singers, would sound exactly alike when a single note of the same frequency was played or sung.

For instance, if middle "C" were struck on the piano, the same note played on a violin or other musical instrument, or sung by a vocalist, and all overtones of the note eliminated leaving only the funda-

mental, it would be impossible to tell one instrument from another, or that the note was sung by a human voice. Please read this paragraph over again, for it has an important bearing on what is to follow.

In Fig. 3, is shown an oboe with a fundamental note and the overtones graphically illustrated. You will note this instrument has a large number of overtones or harmonics, as has also the human voice shown



FIG. 3

in Fig. 4. However, the piano (Fig. 5) has comparatively few overtones as compared with other instruments, and its individuality is due to its ability to produce almost pure fundamentals. It is for this reason that a piano is generally used as the standard to tune other musical instruments. Although not as rich in overtones, the piano has a wide range of fundamental frequencies, running with overtones from about 70 to over 6000 cycles, so you will see that the average radio fails to reproduce many of the fundamentals



FIG. 4

or overtones of one of the musical world's most versatile instruments.

Fig. 6 shows the frequencies audible to the human ear, and you will notice that these range from 25 to as high as 16,000 cycles per second. On the ordinary radio receiver you hear approximately 25% of the audible frequency range, that is, the notes between



FIG. 5

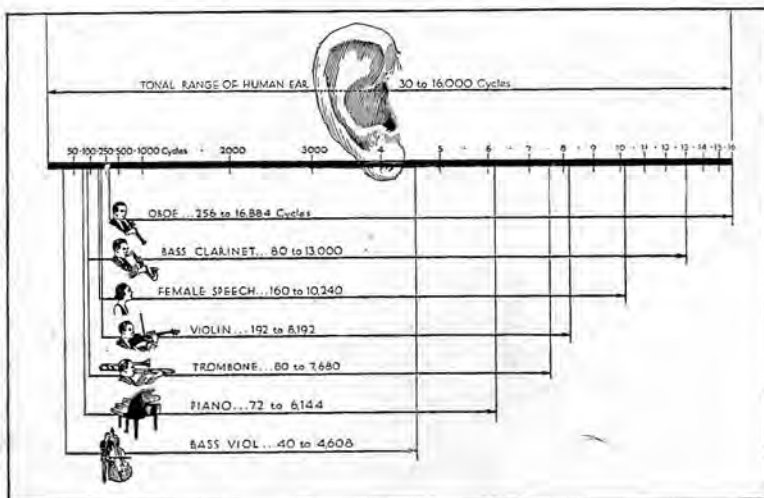

FIG. 6

100 and 4000 cycles. On the new High Fidelity Receivers recently introduced, you are able to hear approximately 50% of the musical tones and sounds audible to the human ear, but only on the new Scott Full Range High Fidelity Receivers, is it possible to hear the full range of musical sounds and tones that are audible to you when listening to musical instruments or vocalists in person. (See Fig. 6 which shows the frequency range of the various type of radio receivers and the new Scott Full Range High Fidelity Receiver.) Any radio receiver that cannot produce all of the musical sounds that

our ear is capable of hearing, cannot bring a radio program to you in all of its realism.

Full Range reproduction is secured on the new Scott Full Range High Fidelity Receiver thru the medium of two knobs on the front panel. One, the Bass Control, controls the bass frequency response, and the other, the High-Fidelity Control, controls the frequencies which lie in the higher register.

In Fig. 7 is graphically illustrated the action of the High-Fidelity Control, at four different positions. As an actual fact, however, this control is CONTINUOUSLY VARIABLE between the points shown. For

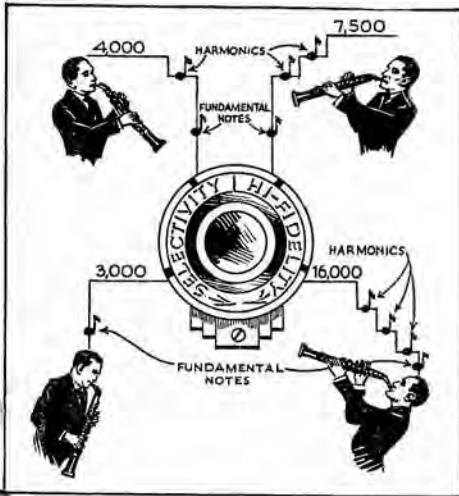

FIG. 7

the purpose of illustration, I have taken an oboe with imaginary notes coming from it. In the first position, only frequencies up to 3000 cycles per second will be reproduced, those above that point being cut off. In No. 2 position, frequencies up to approximately 4000 cycles will be reproduced, which now includes not only the fundamental, but also a few overtones of the fundamental notes below 3000 cycles. At position No. 3, the fidelity range is increased to 7500 cycles with a corresponding increase in the range of overtones that will be reproduced. At its maximum position, No. 4, all frequencies up

to 16,000 cycles per second will be reproduced, which brings to you every fundamental and overtone that you could hear were the instrument being played for you.

Very often the pleasure of various musical programs can be increased by accentuating, or subduing slightly, the bass or lower frequency response. You may prefer a deep rich tone, and this can easily be secured with a touch of the Bass Control. In Fig. 9 its action is graphically illustrated, with the bass viol as an example. As this control is moved from the minimum to maximum position, the bass notes coming in will be accentuated and made louder as illustrated by the increasing size of the bass viol as this control is turned, without, however, altering the high frequency response in the slightest. On the other hand, if you are listening to a selection in which the bass is too strong, or if you prefer the brilliancy of the higher pitched instruments, simply turn this control back, and it will immediately reduce the strength of the bass to a level more pleasing to your ears.

Scott Receivers are not built just for this year or next year's reception conditions. Its design, construction and appearance make it immediately apparent that it is a radio receiver designed for the future, as well as for today. When I built the first Scott Receiver capable of giving consistent short wave reception in 1929, there were no other commercial radio receivers being built then that would do this. For nearly four years I was alone in the field, and it was not until the end of 1933 that other radio manufacturers even began to give consideration to short wave reception, and started building receivers capable of bringing in programs on the short waves, as well as the broadcast band. Today a receiver that does not tune the short waves as well as the broadcast band is obsolete.

I confidently predict that within the next few years, the present scheme of allocation of broadcast frequencies will be changed, allowing for a separation between channels of 20 Kc. When this time arrives, the receiver with the limited frequency range will be obsolete, for only one covering the full

range from 25 to 16,000 cycles will be capable of reproducing all of the frequencies transmitted from these broadcast stations. An article in the June, 1935, issue of Electronics, entitled "Some Possibilities of Synchronizing" shows how it is possible to reallocate the broadcast band frequencies and by synchronizing secure 20 Kc. channels and so allow all of the more powerful stations to transmit full range high fidelity, or 25 to 16,000 cycles at all times.

As I have said before, the new Scott Full Range High Fidelity Receiver is designed not simply for broadcast conditions as we

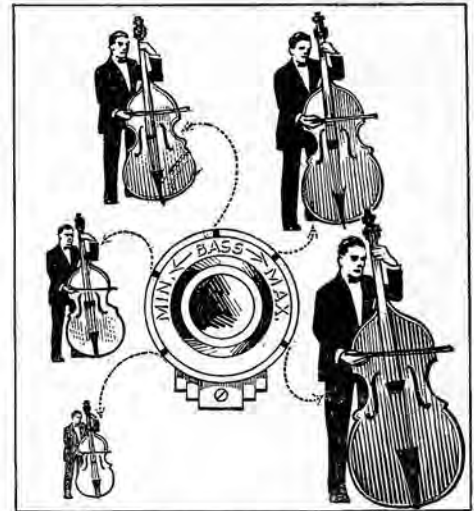

FIG. 9

know them today, but to meet those for many years to come. It will bring to you programs from the stations of the world, with more volume, and better tone, than any other receiver. You, as an owner of this new Scott Receiver, will be amazed by its ability to recreate programs in a way which you have never even dreamed of, let alone thought possible. What you have been missing during all these years when listening to an ordinary radio receiver, will at once be apparent when you listen to the new Scott Full Range High Fidelity Receiver.

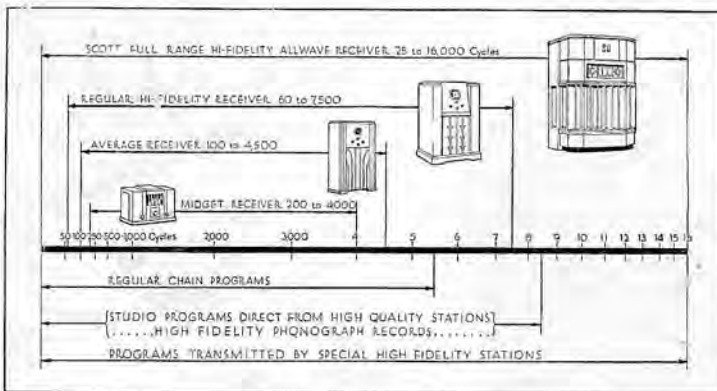
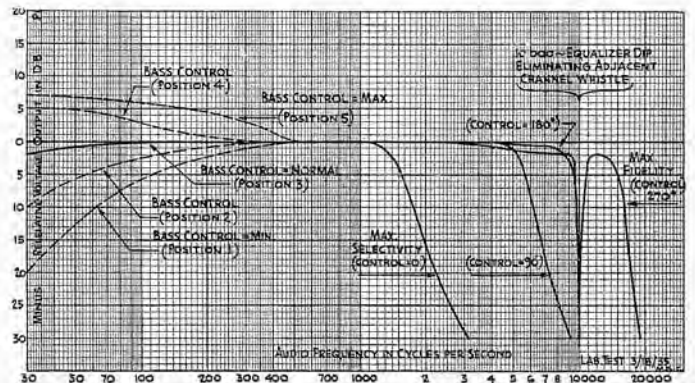

FIG. 8



Overall Audio Frequency Range

A NEW VISTA OPENS FOR LOVERS OF FINE MUSIC

THE ability of the Scott Full Range High Fidelity Radio Receiver to reproduce every note and overtone audible to the human ear, opens up an entirely new vista to music lovers, for it brings to them the tones long known to have been missing in reproduction from the ordinary radio receiver.

It is now possible for them to listen to symphony concerts and recitals by world famous artists, with nearly as much pleasure

High Fidelity reproduction is from the reproduction obtainable thru the ordinary radio receiver with its tonal range of 100 to 4500 cycles, or even an ordinary High Fidelity radio receiver whose tonal range may extend to 7500 cycles. The pictures below show graphically what accounts for this marked difference.

At first glance, you may think that the illustrations of the two orchestras are identical. However, a closer examination will

ment. What your eyes are able to do in this instance, your ears do when you listen to an orchestral selection thru the new Scott Full Range High Fidelity Radio Receiver. No longer will you only hear something which your ears, thru long association with music as it comes over the average radio receiver have learned to interpret as music, but you will actually hear the music as you would if you were seated in front of the orchestra itself.

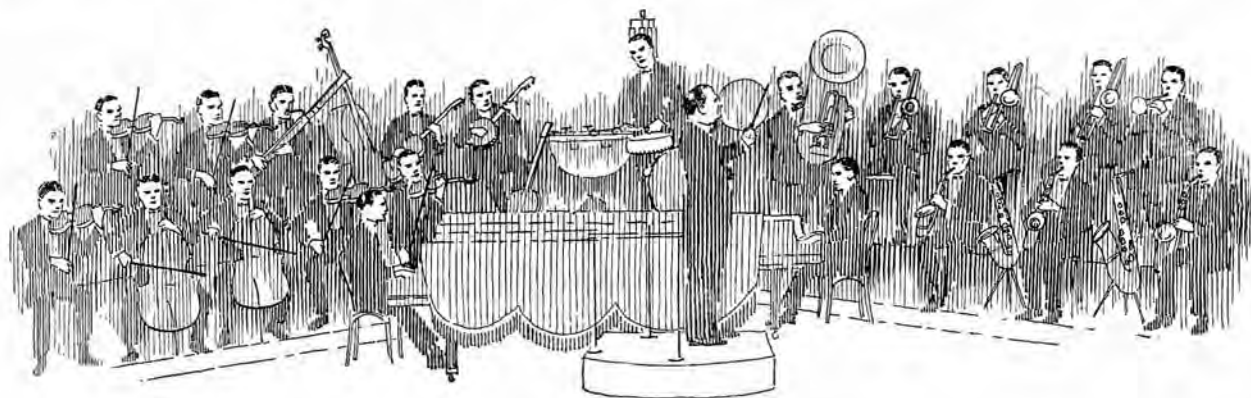

FIG. 1

as if they were in the actual audience. Advanced students of music are now able to listen to broadcasts of outstanding events in the musical world, and study critically the technique of the artist, by following every shade of expression and each pure liquid note of melody.

It is a revelation to those listening for the first time to a symphony orchestra transmitted from a high quality broadcasting station, to note how different Scott Full Range

reveal that they are not. In Fig. 1 the entire orchestra has a hazy appearance. The artists and instruments do not stand out clearly with their true individuality. When looking at this picture you get just a hazy impression, of an orchestra, just as your ears get this same impression of a conglomeration of sounds when listening to an orchestral selection over the average radio receiver. Now look at Fig. 2. Note how easy it is for your eyes to pick out and identify each instru-

The degree of tonal perfection obtained is startling when first heard. This perfection is the result of many years of constant research and experience in designing and building the highest type of radio receiver. The new Scott Full Range High Fidelity Receiver is today the accepted standard in the radio industry by which other receivers are judged, not only in U. S. A., but in 146 foreign countries where Scott Receivers have been in daily use for many years.



FIG. 2

WHY MORE VERIFIED WORLD'S DX RECEPTION RECORDS ARE HELD BY SCOTT RECEIVERS THAN ANY OTHER RADIO

DURING the past ten years I have repeatedly challenged the whole world of radio to any kind of competitive test, but during this period not a single manufacturer has been willing to accept this challenge. Scott Receivers have established not one, but a number of World's Records in DX Reception, everyone of which has been based on reception *that was fully verified by the stations whose programs were tuned in.*

In 1924, over 10 years ago, the Scott World's Record Super 8, amazed the radio world by establishing a new World's Record for the reception of stations six to nine thousand miles distant, at a period when reception of stations 500 to 1000 miles away was considered remarkable.

Each succeeding Scott Receiver has established new standards for DX reception. Between June 1931 and June 1932, a Scott Allwave Receiver proved, in a test that was conducted not merely for a few days or a few weeks, but over a period of 12 consecutive months, *that programs from stations over nine thousand miles away could be tuned in regularly and consistently every week and every month of the year.*

In this test every single program transmitted from VK2ME, Sydney, Australia, and every program (with the exception of three) from VK3ME, Melbourne Australia, was not only received and logged, but to make proof additionally positive, from three to twenty 12" aluminum records were made of each transmission. This latter fact alone shows the clarity and volume with which these stations were received.

A special 14 page booklet entitled "Proof," which fully describes this test,

will be sent to anyone interested in complete details and verifications of this remarkable record.

The reputation of Scott Receivers for the consistent, regular reception of programs from stations up to ten thousand miles distant is well known, not only in U.S.A. but in practically every country in the world, for they are now in daily use in 146 different foreign countries. The curves reproduced on this page provide a complete explanation to those familiar with laboratory measurements of a radio receiver, why a Scott Receiver is able to bring in programs from distant stations with such volume and clarity.

Usually when selectivity is mentioned,

you think of it being good when it is in the order of 10 Kc., because this is the separation of American Broadcasting Stations. However, the new Scott Full Range High Fidelity Receiver establishes an entirely new standard in Selectivity. Any degree of Selectivity from 2 Kc. minimum to 16 Kc. maximum, can be secured, and is continuously variable throughout this range. For example, here in Chicago, it can separate two of the world's most powerful broadcasting stations, namely, WGN, Chicago, 50,000 watts; WLW, Cincinnati, 500,000 watts, and bring in WOR, Newark, 50,000 watts, with no interference from WGN or WLW. No other receiver in the world offers such a high degree of selectivity.

It is generally conceded in the radio industry that Scott Receivers are built to a higher standard of precision than any other receiver in the world today. Those who have never had the opportunity of actually examining one, and noting the fine points of its construction, will be interested in the photographs on the following pages which show, not merely the outside, but what is underneath the shield cans and chassis.

A study of the performance curves on this page, and the photographs on the following pages, and a comparison of them with any other receiver will quickly convince you there is a very firm basis for the claim that the Scott Full Range High Fidelity Receiver is truly, **THE WORLD'S FINEST RADIO RECEIVER.**

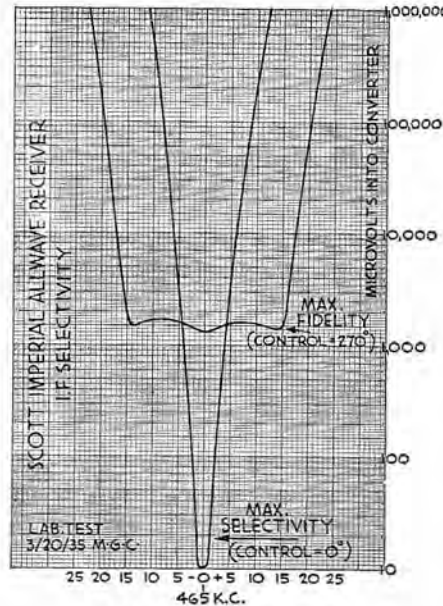

Selectivity Curve

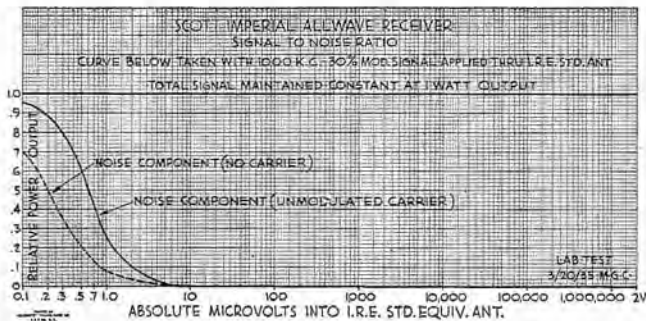

Signal to Noise Ratio

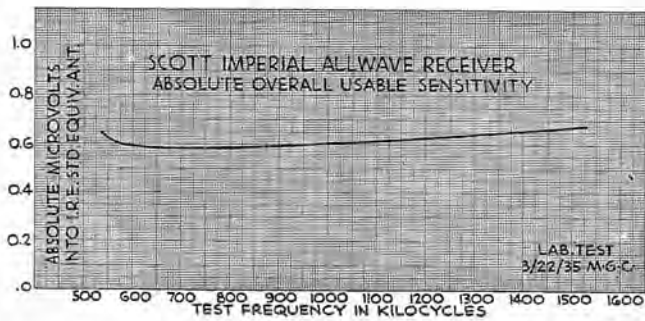

Absolute Overall Useable Sensitivity

A NEW ERA IN MUSICAL REPRODUCTION IN THE HOME

YOU will recall that in the early days of radio before loud speakers came into general use, headphones were used. If there was only one pair of headphones in the house, only one member of the family could listen at a time—the rest had to wait their turn.

With advent of the loud speaker, a new era in radio enjoyment was opened when all persons in the room could listen at the same time. However, from that time until the recent introduction of the Scott Full Range High Fidelity Receiver, no improvement has been made in the degree of *listening enjoyment* available to all the persons in the room, *regardless of where they were seated*. Sound distribution by the ordinary radio

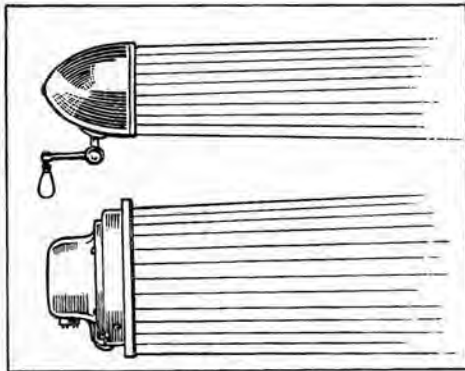

FIG. 1

HIGH FREQUENCY NOTES TRAVEL IN STRAIGHT LINE LIKE BEAM FROM SPOT LIGHT, AND ARE ONLY HEARD 100% DIRECTLY IN FRONT OF SPEAKER.

with one or two speakers installed in a regular type console, is still in the "head-phone" class as far as perfect distribution of music or voice to all parts of the room is concerned.

On the preceding pages you have learned how the Scott Full Range High Fidelity Receiver gives faithful reproduction of all audible frequencies from 25 to 16,000 cycles, and why such reproduction is desirable. You have seen how the Scott Fidelity Control and Bass Compensation Control contribute to its ability to obtain this high quality of reproduction.

With the introduction of the "Tone Truth" sound chamber, a development of our research laboratory with which all Scott Consoles are now equipped, the boomy unnatural tone was eliminated,

but the new Scott Full Range High Fidelity Receiver with its ability to reproduce the full tonal range audible to the human ear presented a new problem in securing perfect distribution of the high frequencies it was capable of reproducing to listeners in every part of the room. In order to understand the problems involved, you will find it interesting to study briefly the action of sound waves at various frequencies and why three speakers are necessary to secure complete room coverage of all frequencies.

The sound waves, or notes, from a high frequency speaker are extremely directional, and can be compared to the light beam of an automobile search light which projects its rays forward in a straight line, leaving objects to the sides of these rays in darkness, as illustrated in Fig. 1. In addition to the high frequencies from the special high frequency speakers, the large speaker also transmits a certain amount of high frequencies from the center of the cone up to 8000 or 9000 cycles.

However, the lower or medium frequency sounds or notes behave in an entirely different manner to the high frequency notes. These travel outward from the cone of the large speaker in all directions, with practically no difference in intensity and can be heard

equally well in all parts of the room, just as the light rays from an ordinary incandescent bulb radiates in all directions, see Fig. 2.

Because of this difference in the action in the distribution of the lower and higher frequencies, it was found necessary to devote considerable time and study to the proper distribution of sound in a typical room, so that all frequencies, both low and high, could be heard in all parts of the room with full realism.

In Fig. 3, is shown an ordinary radio receiver with one speaker, with listeners in various parts of the room. The light shaded lines coming from the speaker represent the higher frequencies. You will note that only the listener directly



FIG. 2

LOW AND MEDIUM FREQUENCY NOTES SPREAD EQUALLY OVER ROOM IN ALL DIRECTIONS, JUST AS LIGHT FROM ORDINARY ELECTRIC BULB ILLUMINATES ALL PARTS OF ROOM.

in front of the receiver is able to hear perfectly the higher frequencies. However, due to the fact that the low and medium frequency sounds travel in all directions, they are heard equally well by listeners in any part of the room. From this you can see that everyone in the room is not able to enjoy the full beauty of a program when seated at either side of a radio receiver equipped with only one speaker, even though it may be designed to give some degree of high fidelity reproduction.

In Fig. 4, is shown the same room setting with a receiver having two speakers, one being a low and medium frequency speaker, the other a high frequency speaker. With this arrangement, the dis-



THE TWO HIGH AND THE LOW AND MEDIUM FREQUENCY SPEAKERS.

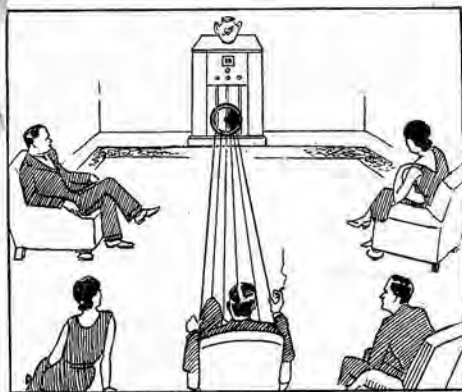

FIG. 3
SOUND DISTRIBUTION OF HIGH FREQUENCIES WITH ONE SPEAKER.

tribution of the higher frequencies is a little better, but is only heard clearly by the person directly in front of the receiver.

Although you may not be technically minded, you can see from this diagram, that even a receiver with two speakers, one large low and medium frequency, and one high frequency speaker, will fail to give full room coverage of all sounds produced, because the higher frequency notes or sounds still do not reach the listeners who are seated at either side of the receiver.

In Fig. 5, is illustrated the sound distribution secured in the same room with the same group of people with the Scott Three Speaker System. The high frequency speakers are installed in the console in such a way that they are a little above and to either side of the large speaker, and set at an angle so as to distribute the high frequencies to the sides and toward the end of the room. The high frequencies coming from the large speaker added to the output obtained from the two small high frequency speakers, give all of the listeners in the room the full audible range, irrespective of where they are seated.

Remembering that the low and medium frequencies are distributed evenly throughout the room, you can now understand why it is necessary to use three speakers to secure full room coverage of all frequencies from 25 to 16,000 cycles.

Depth is thus added to the recreation of the program heard from these speakers, just as you will recall that depth is added to pictures when you look at them through a stereoscope. All listeners, irrespective of the part of the room where they are seated, will thrill to the illusion of realism when the program is recreated for them by the Scott Full Range High Fidelity Receiver.

Before the development of the Scott Full Range High Fidelity Receiver was completed, it was realized that no loud

speakers were available for a radio receiver which would handle either the tremendous output or the extreme frequency range it was being designed to cover. The high frequency speakers were developed for us by a large speaker manufacturer from specifications supplied him by our Laboratory, and used for the first time in the Scott Full Range High Fidelity Receiver, and have an audible frequency range of from 2000 to 16,000 cycles.

The low and medium frequency Auditorium type speaker is also the result of many months of intensive research to produce a speaker for our new receiver that would handle the full output without distortion, and at the same time, have a wide frequency range. It makes use, for the first time, of the latest de-

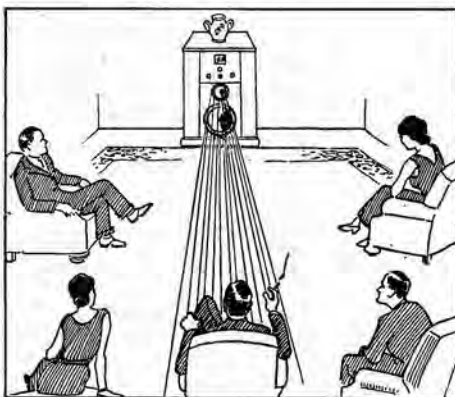

FIG. 4
SOUND DISTRIBUTION OF HIGH FREQUENCIES WITH ONE HIGH FREQUENCY SPEAKER AND ONE MEDIUM AND LOW FREQUENCY SPEAKER.

velopment in radio loud speaker design, the curvilinear cone. The sides of the cone are curved instead of being perfectly straight, and accomplishes a remarkable reduction in secondary distortion, and gives a more uniform frequency response and extension in the frequency range.

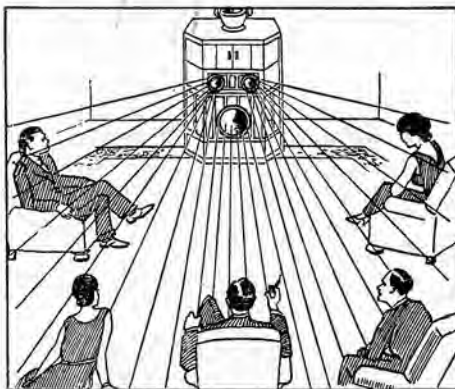

FIG. 5
SOUND DISTRIBUTION WITH TWO HIGH FREQUENCY AND ONE MEDIUM AND LOW FREQUENCY SPEAKER.

World-Wide Reception with Scott Broadcast and Short Wave Battery Receiver Guaranteed

THERE are thousands of locations in various parts of the world where alternating current is not available. In such locations, to secure reception, a battery receiver must be used. Many hundreds of requests have come to the Laboratory asking if we could supply a battery receiver which would give performance comparable to our A.C. receiver. This is a large order. However, after two years' development, we can now announce a Scott Battery Receiver, with 11 tubes, which fully measures up to the high standards set by the Scott A.C. Receiver.

The same high quality parts, precision construction and advanced design, has gone into our battery set that goes into our A.C. model. No longer is it necessary for those who do not have alternating current, but who desire to listen regularly to stations in all parts of the world, to deprive themselves of this kind of reception. With the new Scott 2 Volt 11 tube battery receiver, stations from all parts of the world can be brought into your home with loud speaker volume and tone quality comparable to a receiver operating from alternating current.

The Ever-ready Air Cell "A" battery will operate the receiver an average of three hours a day for nearly a year before it needs to be replaced, and the four heavy duty "B" batteries, and the small "C" battery, will operate the set for approximately six months, if used on an average of three hours daily.

A few of the outstanding features of the Scott Broadcast and Short Wave Battery receiver:

- (1) Advanced Superheterodyne circuit.
- (2) Covers all wave lengths from 13 to 555 meters on four bands, using the same perfected wave changing mechanism used in the new Scott Full Range High Fidelity A. C. Receiver.
- (3) Dial calibrated accurately in Kilocycles and Megacycles, with each wave band designated with distinct color, making it easy to read.
- (4) Illuminated dual ratio tuning dial—fast tuning for broadcast stations, and slow tuning for foreign short wave stations.
- (5) Automatic Volume Control, which greatly minimizes the fading of programs from distant stations.
- (6) 10" Permanent Magnet Dynamic Speaker, with output of 4 watts.
- (7) Eleven latest low-drain 2 volt battery tubes of the following types: 4 Type 34; 6 Type 30, and 1 Type 1A6.

If you are interested in the ultimate in battery receivers, we will be glad to send you detailed information upon request.

Circuit and Constructional Details That Make the Scott Full Range High Fidelity Receiver the World's Finest Radio

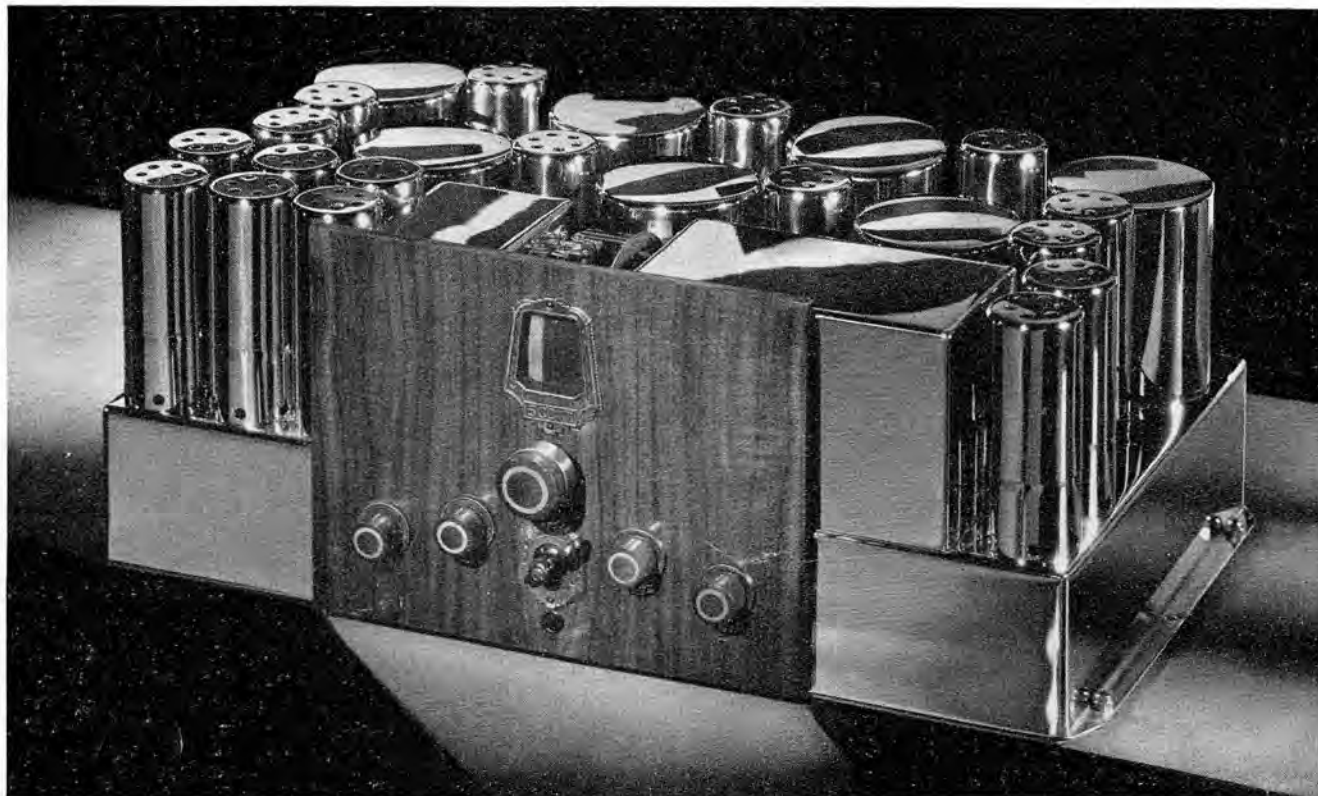

THE SCOTT FULL RANGE HIGH FIDELITY RECEIVER CHASSIS

YOU can't judge a book by its cover," and it is equally true "You can't judge a radio receiver by its console." A beautiful console is very desirable. However, it is not the console that brings the program into your home, but the radio chassis installed inside of it.

It is not a difficult matter to design a compact radio chassis, but if maximum efficiency and performance are desired, the chassis cannot be of the vest-pocket variety. A baguette watch, while extremely small and compact, is not the kind carried by the railroad engineer, because he needs a time-piece on whose accuracy he can depend month after month, and year after year.

The dependability of a railroad engineer's watch is due to the fact that it is of ample size, has high quality parts large enough to maintain their accuracy for many years, and is built, adjusted,

and tested by highly skilled craftsmen. A small, compact receiver can never give the kind of reception you will secure from one designed with the same ideals of accuracy, precision, and long life in mind, as the watch carried by the railroad engineer.

Prospective purchasers of a radio receiver will find it extremely interesting, after looking at the front of a set, to walk around to the back and examine what is inside the console. In many instances, you find you require a microscope almost, to discover that part of the instrument you are really paying for, the chassis and speaker that bring the program to you.

One reason for the photographs appearing on these pages is to show you exactly what a Scott chassis looks like inside and out, with the perfection in mechanical design, and fine craftsmanship that goes into the parts of it you cannot see.

Incorporated in the new Scott Full Range High Fidelity Receiver is every modern development of proved value in radio receiver design. In it you will find a number of exclusive circuits and mechanical features which are not incorporated in any other receiver, and are the result of the active research of our own Laboratories.

Many people are under the impression that certain large companies such as the Radio Corporation of America, General Electric, American Telephone and Telegraph, Westinghouse Electric and Manufacturing Company, etc., incorporate in their receivers developments which cannot be used in our receiver. This is not so, for under our patent licensing agreement, we have available, should we desire to use them, every radio patent for radio receivers sold for broadcast and entertainment purposes owned by Radio Corporation of America, General Elec-

ic, American Telephone and Telegraph, Westinghouse Electric and Manufacturing Company, and the Hazeltine Corporation. This information is given so that the prospective purchaser of a Scott Receiver can be assured that every development of these companies that is considered worth while by the Scott Laboratories can be incorporated in a Scott Receiver.

However, the many exclusive patented Scott features developed in the Scott Radio Laboratories are incorporated only in Scott Receivers and are not available to these companies for inclusion in their receivers.

Those who appreciate perfection in mechanical design and construction will instantly recognize that the New Scott Full Range High Fidelity Receiver is no ordinary radio, but a marvel of me-

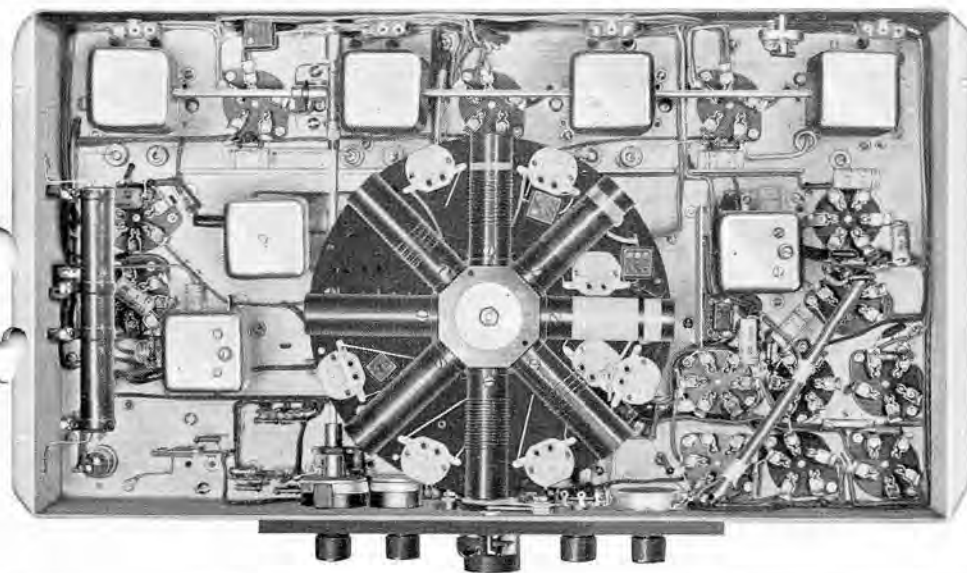
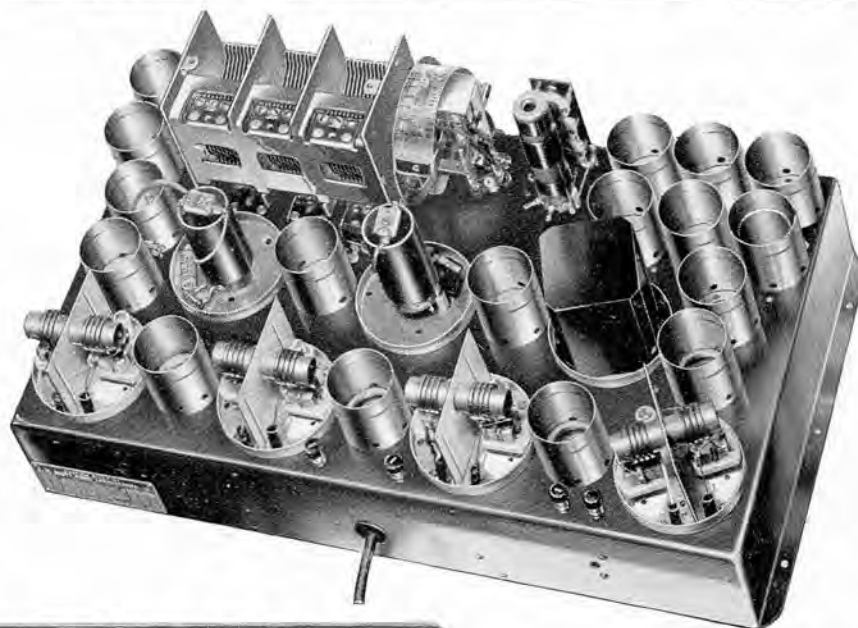

chanical achievement. Practically every part of it has been especially designed, and is built in our own Laboratory. You are invited to visit us, when we will be glad, not only to demonstrate this marvelous new instrument, but take you through the laboratories and show you every step in its development, construction and test.

THE PHOTOGRAPH ABOVE SHOWS VIEW OF CHASSIS WITH COIL SHIELD CANS AND CONDENSER COVER REMOVED. THE VIEW AT SIDE SHOWS CHASSIS WITH BOTTOM PLATE REMOVED. NO OTHER RECEIVER IN THE WORLD IS BUILT WITH THE PRECISION OF THE SCOTT FULL RANGE HIGH FIDELITY RECEIVER.

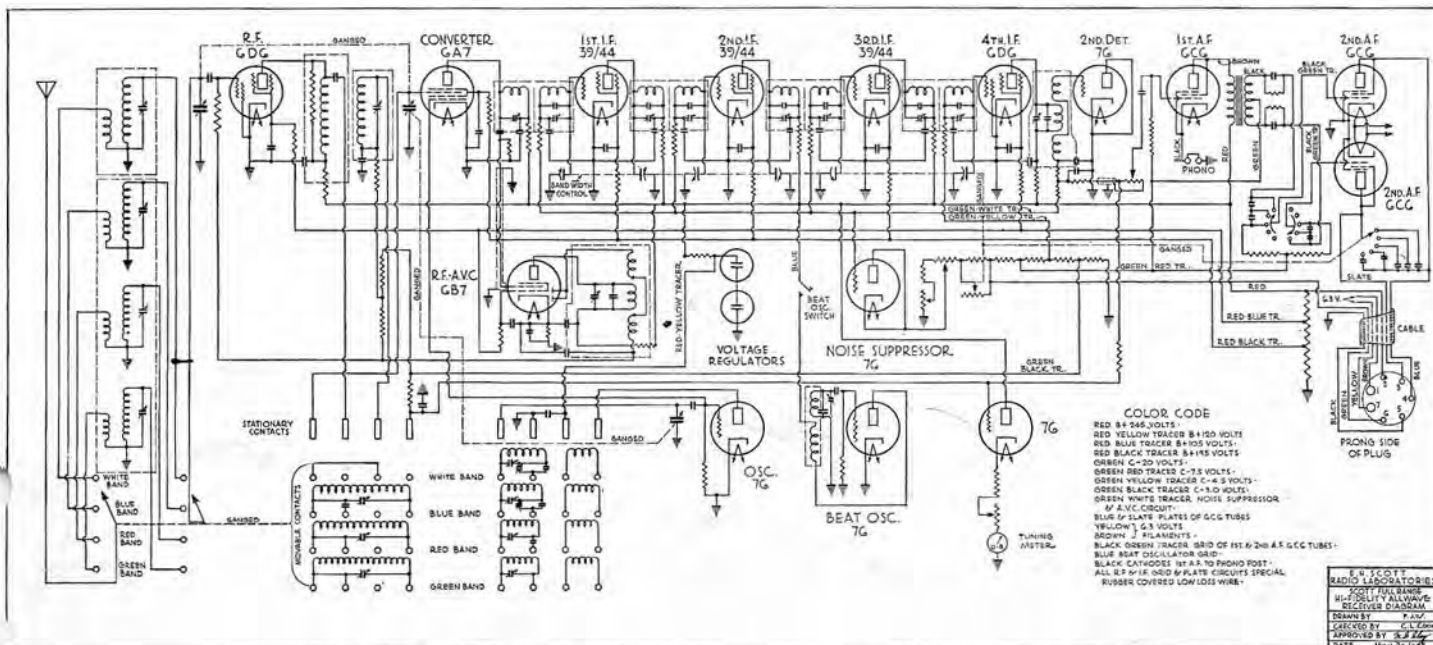

CIRCUIT WIRING DIAGRAM OF SCOTT FULL RANGE HIGH FIDELITY RECEIVER.

E. S. SCOTT
 RADIO LABORATORIES
 HIGHER FIDELITY ALWAYS
 RECEIVED DIAGRAM
 DRAWN BY P. J. W.
 CHECKED BY C. L. L.
 APPROVED BY E. S. S.
 DATE May 29, 1938

A FEW OF THE PRECISION UNITS BUILT INTO THE SCOTT FULL RANGE HIGH FIDELITY RECEIVER

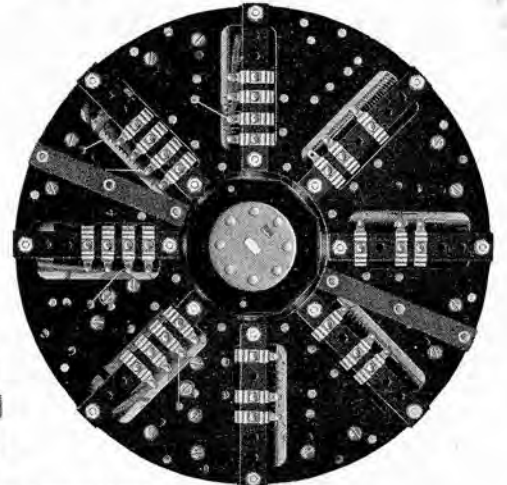
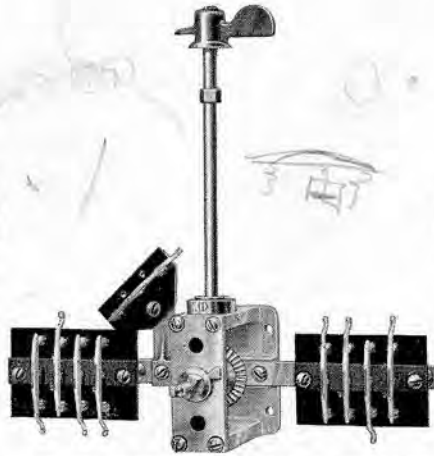
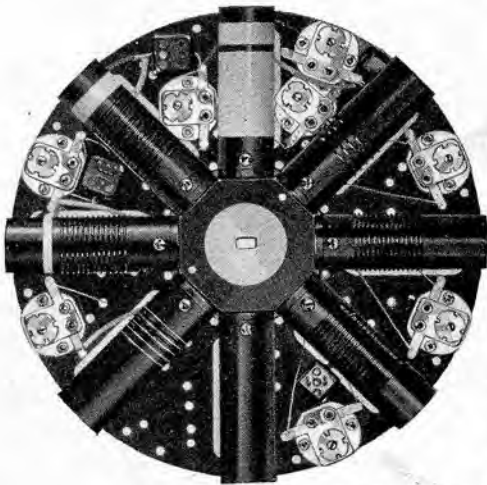

THREE VIEWS OF THE EXCLUSIVE SCOTT WAVE CHANGING MECHANISM.

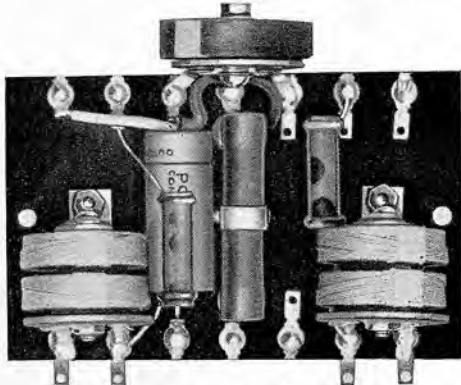

SPECIAL 10,000 CYCLE ATTENUATOR UNIT.

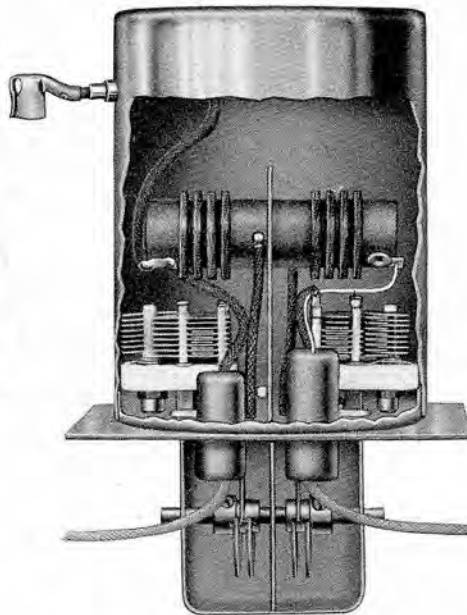

CUT AWAY VIEW OF HIGHLY DEVELOPED SCOTT AIR TUNED I. F. TRANSFORMER UNIT.

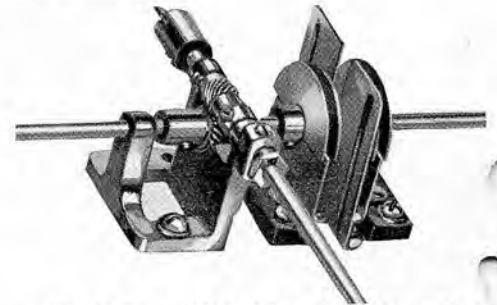

PRECISION WORM GEAR DRIVING MECHANISM FOR HIGH FIDELITY CONTROL.

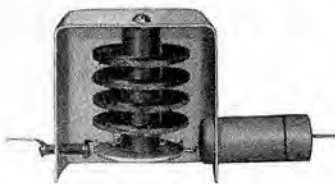

CUT AWAY VIEW OF FOUR PI. R. F. PLATE CHOKE.

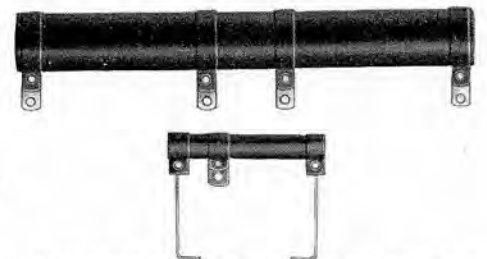

OVERSIZED SCOTT VOLTAGE DIVIDER COMPARED WITH UNIT USED IN OTHER RECEIVERS.

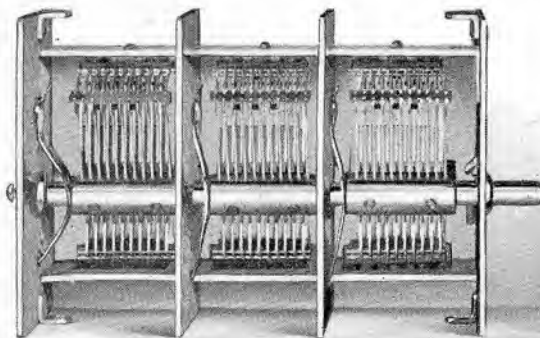

SCOTT VARIABLE TUNING CONDENSER WITH ITS HEAVY RUGGED PLATES AND BEARINGS, COMPARED WITH VARIABLE CONDENSER USED IN OTHER RECEIVERS.

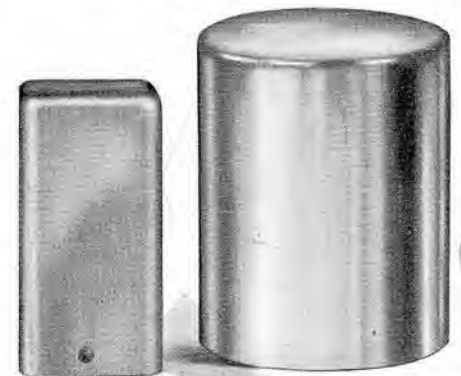
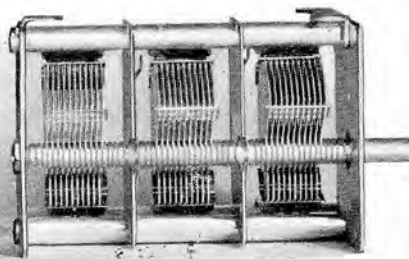

SCOTT COIL SHIELD CAN COMPARED WITH STANDARD SIZE.

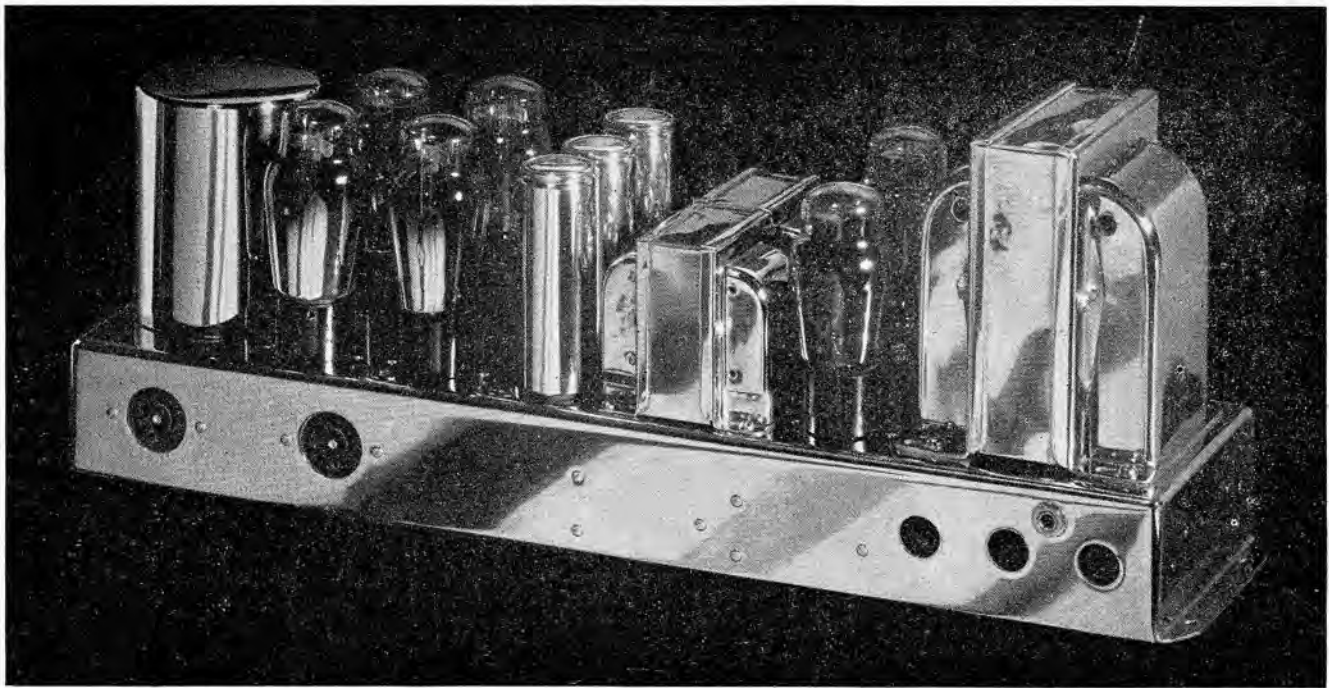

TOP VIEW OF THE SEPARATE POWER AMPLIFIER FOR THE SCOTT FULL RANGE HIGH FIDELITY RECEIVER

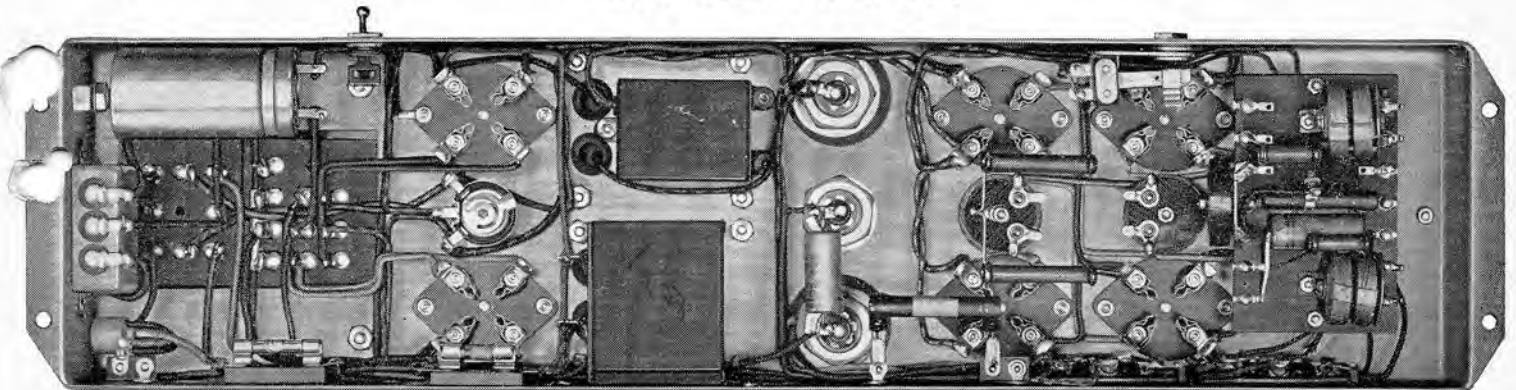

BOTTOM VIEW OF POWER AMPLIFIER

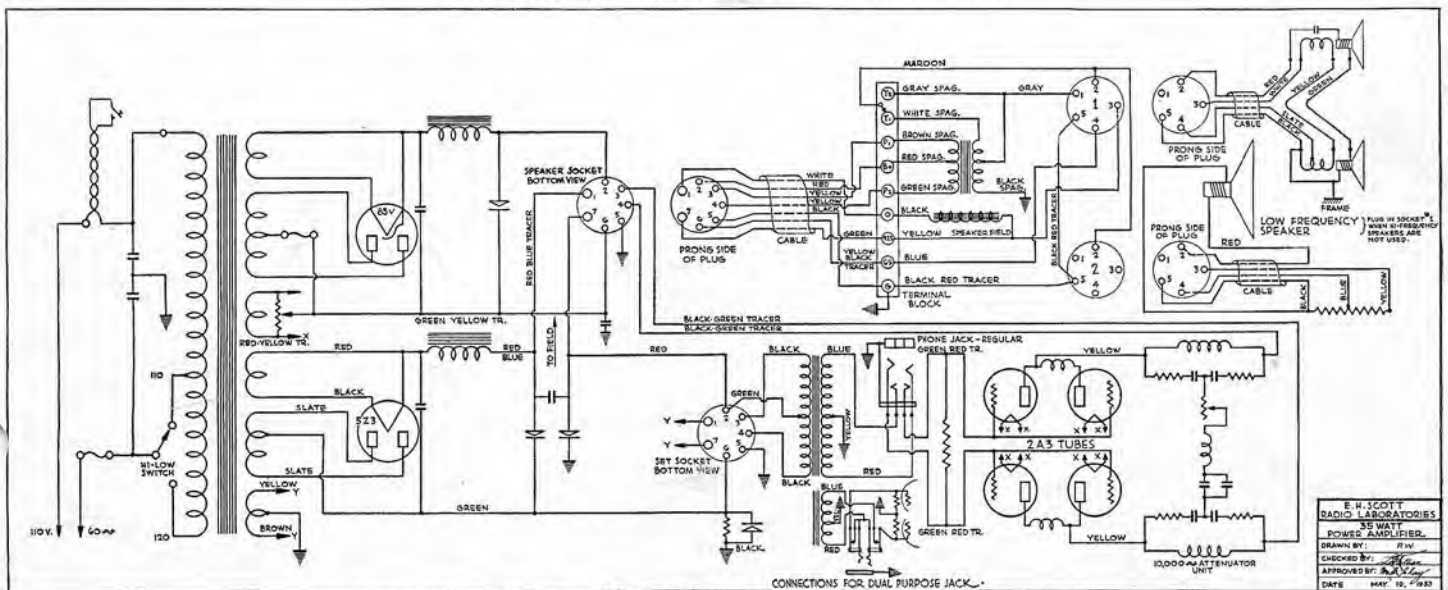

CIRCUIT WIRING DIAGRAM OF POWER AMPLIFIER

E. H. SCOTT
 RADIO LABORATORIES
 35 WATT
 POWER AMPLIFIER
 DRAWN BY: R. W.
 CHECKED BY: [Signature]
 APPROVED BY: [Signature]
 DATE: MAY 18, 1937

The Scott News

Published Frequently at Chicago by
E. H. SCOTT RADIO LABORATORIES
Chicago

E. H. SCOTT, Editor

THE CUSTOMER IS ALWAYS FIRST!

During the past few weeks there has been a considerable amount of publicity given a new type of tube with a metal, instead of glass envelope.

Here at the Scott Laboratory I keep a very open mind on every new development, and my research laboratories investigate all of them as soon as they appear. When rumors first began to circulate about metal tubes some six months ago, I was very much interested. About four months ago I received our first samples of them, and immediately built a number of experimental models for practical test. A careful analysis confirms the following points about metal tubes.



E. H. SCOTT

- 1—They are new.
- 2—They are more compact than glass tubes.
- 3—They are *partially* self-shielding.
- 4—They will enable manufacturers of radio receivers in the moderately priced class to design sets slightly smaller in size, and sell them to the public at a slightly lower price.
- 5—When manufacturing processes have been perfected, a slight decrease in cost of tubes can be expected, owing to the fact that about six metal covers can be stamped out for the same price it now costs to blow one glass cover.

The above, I believe, represents every possible advantage that can be claimed today for the use of metal tubes in a radio receiver. In my opinion, however, the disadvantages of metal tubes far outweigh the few advantages. I believe you will be interested in learning from someone, *not a tube manufacturer*, the other side of the metal tube picture.

(1) Tests on metal tubes used by us so far have shown that apparently the manufacture of them has not so far been perfected to the point where a large number of metal tubes can be manufactured with characteristics which are as uniform as the present highly developed glass type tubes.

(2) Operating temperature of several of

the metal type tubes is extremely high. In fact, it is quite impossible to touch them *without seriously burning the fingers*, and so hot that a piece of solder placed on top of the tube can be melted in a short time.

(3) Metal tubes when used in *highly developed sensitive receivers are not completely self-shielding in themselves, but require an additional shield to cover the most sensitive part of the tube—the top grid cap*. The fact that such shielding is *not* necessary in some receivers, is rather conclusive proof that the degree of sensitivity of the receiver is not great.

(4) Metal tubes positively do *not* eliminate receiver noises on account of their shielding, as has been claimed in many descriptions of this tube in recent advertisements. At least 95% of the noise from a carefully designed radio receiver comes from static and electrical interference picked up by the antenna, *and this type of noise is not eliminated nor is it reduced any more with metal tubes than it is with our present type glass tubes*.

(5) Metal tubes do not improve the tonal reproduction, range, or power output. The most powerful metal output tube at present available is the 6F6. When four of these tubes are used as class AB, it is possible to secure 30 watts with 7% distortion, or when used as strict Class A, 10 watts with 2½% distortion. With four 2A3 glass type tubes we can secure over 40 watts Class AB, with 7% distortion, or 33 watts strict Class A with only 2½% distortion.

(6) They are *not* as revolutionary in performance as recent publicity releases and advertisements would lead one to expect but have exactly the same characteristics as the corresponding glass tubes. The principal difference, despite all claims to the contrary, between the metal and glass tubes, is the fact that one tube has a glass envelope, and the other metal; and the biggest asset of the metal tube to the radio industry today, is that it is something "new" to sell the public this Fall. Proof that every characteristic of the metal tube *can be duplicated in a glass tube*, is shown by a recent advertisement published by the RCA Radiotron Company. One week the following paragraph appeared in their advertisements regarding metal tubes:

"RCA all metal tubes are not interchangeable with any glass type."

However, the following week this manufacturer published the following retraction:

"It has been called to our attention that at least one manufacturer is providing glass tubes with Octol bases and characteristics similar to those of RCA metal tubes. We, therefore, wish to withdraw our original statement."

This statement from the principal manufacturer of metal tubes proves quite clearly *that metal tubes are not quite so revolutionary as one might be led to believe after reading the advertisements*.

That the radio industry as a whole is not "sold" on metal tubes is indicated by statements that have appeared during the past week regarding them from three of the larg-

est manufacturers in the industry. One prominent manufacturer has just announced: "They (metal tubes) will be used in our cheaper models, but not in our higher priced ones." Still another says, "Metal tubes will be used in our better models, and glass tubes in the cheaper models"; another one, "You can get any of our models with either glass or metal tubes." Remember, these are not statements from small manufacturers, but from three of the industry's leaders. These various conflicting statements show clearly an attempt to get aboard a band wagon which may possibly capture the public fancy, but which they can jump off of quickly if need be.

The question that naturally comes to one's mind is, "Why, if metal tubes are so revolutionary, and so great an improvement over glass tubes, are they not used exclusively by these manufacturers?" On the other hand, I believe it is equally significant that the largest manufacturer of radio receivers in the world tested metal tubes several months ago, but is supplying all new models with glass tubes exclusively. Their engineering laboratory came to the same conclusion as my own, that is, *that the metal tubes at present offer no advantages over our present highly perfected glass envelope tubes*.

The information given above is an entirely unbiased analysis of metal tubes versus the glass tubes, for I have no axe to grind. It is just as easy for me to supply the new Scott Full Range High Fidelity Receiver with metal tubes as it is with the present highly developed glass tubes, and if my intensive laboratory tests of these tubes had proven that it was possible to *build a better receiver with them*, you would find them as standard equipment in my present receiver.

I will guarantee that the new Scott Full Range High Fidelity Receiver equipped with glass tubes will outperform any receiver equipped with metal tubes. You can purchase it with the distinct understanding you are to be allowed thirty days' trial in your own home to make a comparison test, should you desire, against any receiver equipped with metal tubes. If you can find a receiver equipped with metal tubes that gives better performance than the Scott Full Range High Fidelity Receiver, simply return the Scott any time within thirty days, and your money will be refunded. I don't believe there is a manufacturer of any receiver now using metal tubes that has enough confidence in the performance of his set to make a similar offer. After all, it's performance that counts.

At the Scott laboratories the customer's interests always comes first. When the development of metal tubes has reached the point where they will enable me to build a better receiver than I can now build with the glass tubes, they will be immediately incorporated as a permanent part of the design of my receiver.